

"Owning a Volkswagen is like being in love"





De Luxe Sedan

This is the Volkswagen that has won world fame within only a few years. Its owners claim that it is the most sensible thing on wheels. It is powered by what is believed to be the best designed and most reliable engine ever built within its class. Its economy will put money in your bank, for the car offers a maximum of performance for a minimum of outlay.

*Good visibility in front and behind;
generous windscreen and rear window*

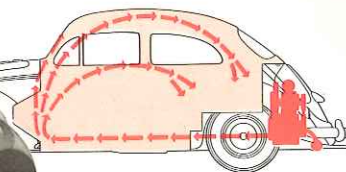
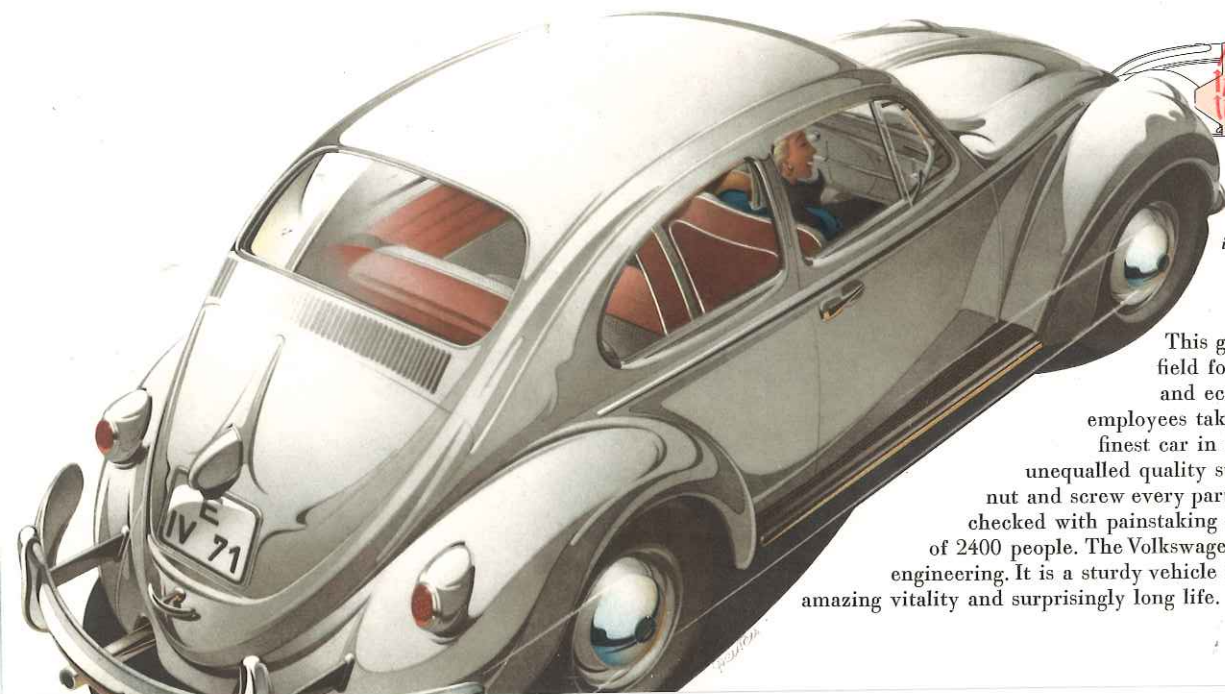
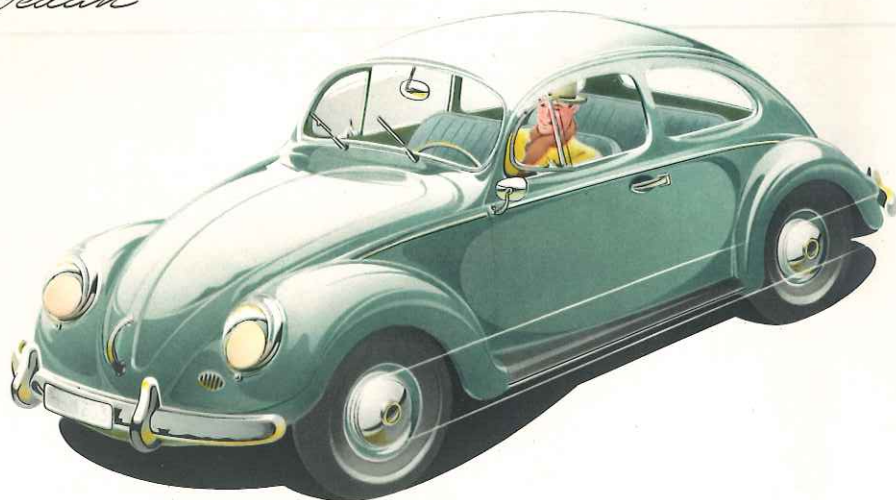
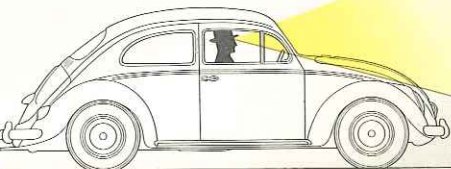

*The built-in heater,
supplied as a standard equipment,
is adjustable to suit every requirement.*

This grand small car is unique in its field for performance, safety, comfort, and economy. 40,000 skilled full-time employees take pride in building the world's finest car in its class and in maintaining its unequalled quality standards. Down to the smallest nut and screw every part is carefully tested and double-checked with painstaking accuracy by an inspection staff of 2400 people. The Volkswagen is a masterpiece of precision engineering. It is a sturdy vehicle built for hard service - with an amazing vitality and surprisingly long life. In fact, it is a class of its own.



Sunroof Sedan

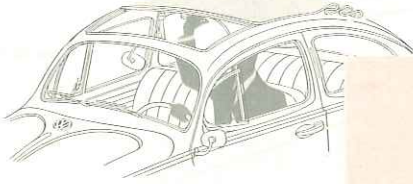

If you have reasons for not choosing a convertible you can combine the heightened enjoyment of open-air driving with the snug coziness of a closed car in a VW Sunroof Sedan. Even when the car is moving fast over the highway, one movement will open or close the Golde Sunroof, or set it in whatever position you like.

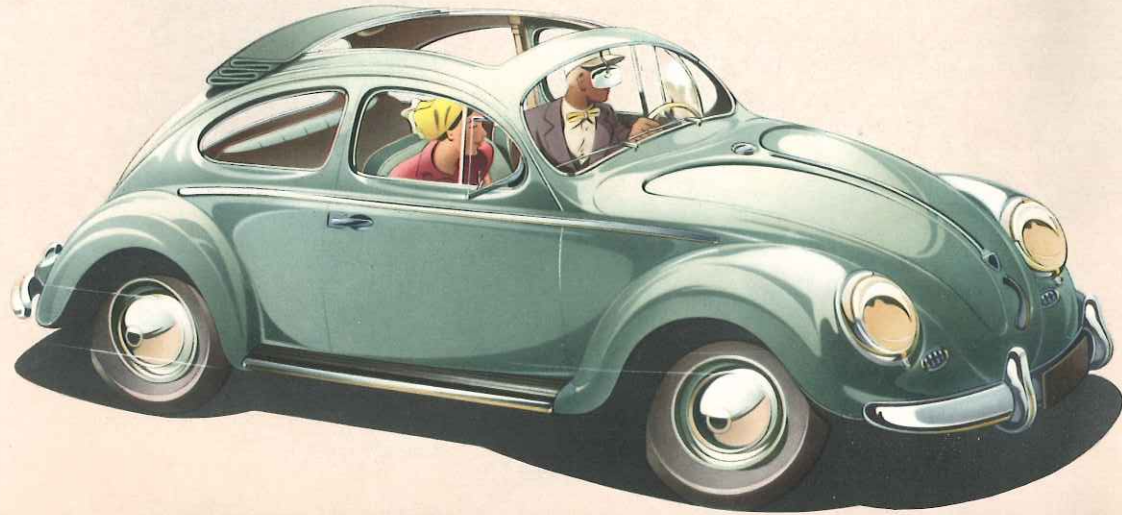

Convertible

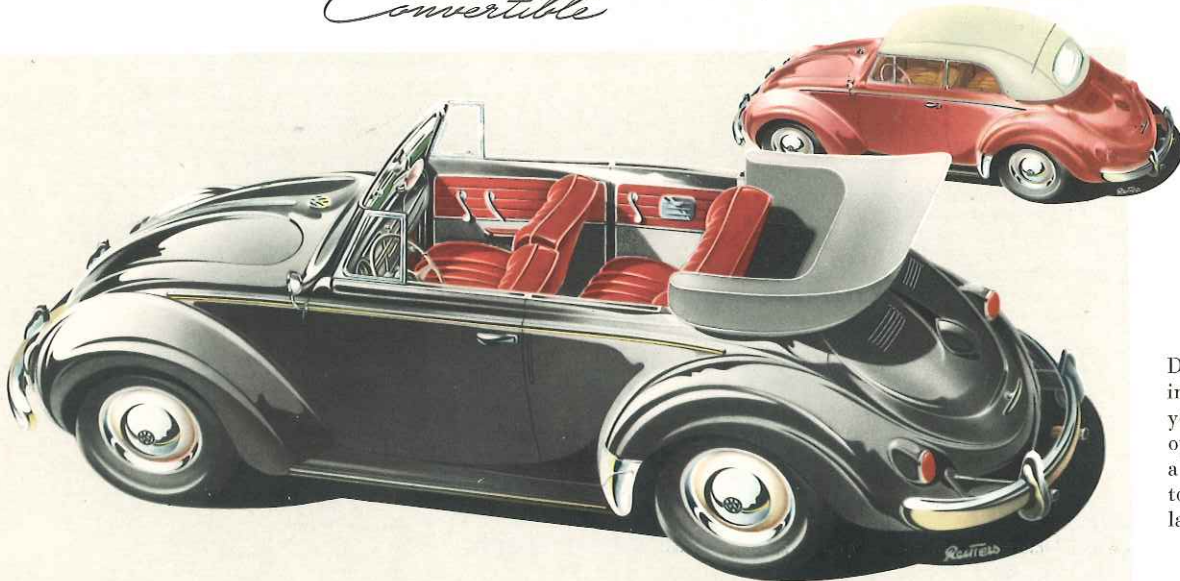

Do you enjoy driving an open car, in fresh air and sunshine? Would you like your car to emphasize your own individuality? If so, you'll pick a Volkswagen Convertible. Needless to add that it's a favourite with the ladies - a sheer treat to drive.

Park it with a smile! Volkswagens are so handy and manoeuvrable that you will usually find a space large enough to get into easily.

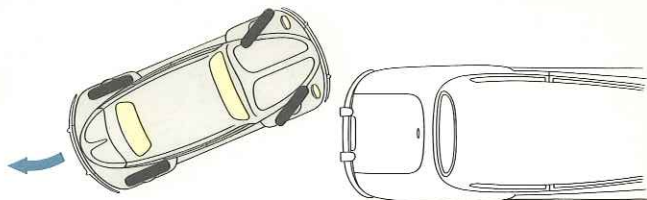
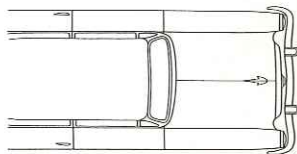

Volkswagen - The Honest Car

In ten short years the Volkswagen has risen from total obscurity to become a household word on every continent, an accepted international yardstick for judging an automobile. Of all the cars exported in the world, the Volkswagen now holds undisputed first place.

The Volkswagen has an ideal sales force: some two million happy owners. No wonder the constantly increasing output at Wolfsburg never catches up with demand.

Why is it that the imagination of two million Volkswagen owners has been fired by this amazing car?

Because of its sensible engineering and sturdy construction.

Because it possesses a combination of performance and economy never before known in automobile design.

Because it does not pretend to be anything but what it is - an honest car.

Because there has been a consistent policy unswayed by whims of fashion, holding fast what has proved itself, yet constantly improving the car and so raising it to an internationally admired pitch of perfection.

The plainest and most gratifying proof of this is the high resale value of a VW. Buying one is a sound and a secure investment.

Driving a Volkswagen is fun, not merely because it is a workmanlike and economical car, but because it is at home everywhere; you are in safe hands wherever you go - those namely of the VW service system with its world-wide and close-meshed network of carefully selected repair shops. It is a fact known the world over:

Volkswagen service is just as good, just as dependable, and just as economical as the unique car it maintains. Behind every Volkswagen service sign stand the professional pride and helpfulness of a full staff of trained VW specialists, devoting their knowledge, their skill, their love of the Volkswagen to all the millions of the VW family.



...EFFICIENT AS THE CAR ITSELF



Volkswagen fittings are handsome and functional; every interior detail has been worked out with discreet elegance and ingenuity. A wide range of colour combinations pleases any taste. Of course the driver has his own form-fitting seat (both

front seats can be individually shifted and their backs adjusted even when the car is in motion). The back seat is just as comfortable as the front. Two luggage compartments offer an amazing amount of room.

Chassis

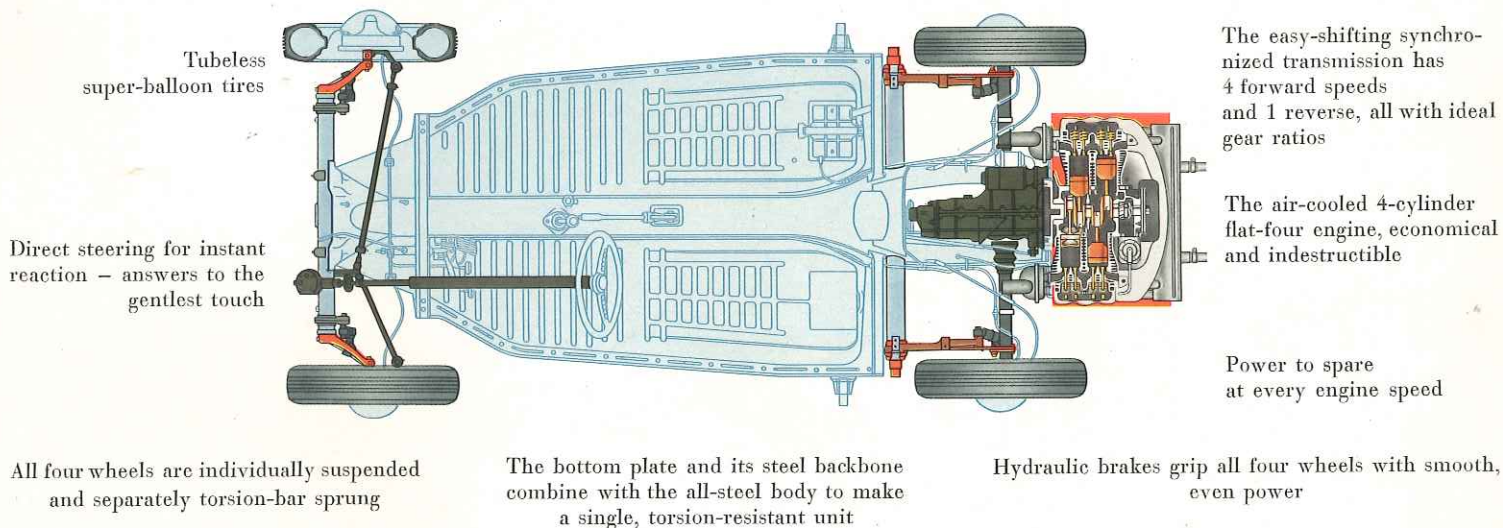

Tubeless
super-balloon tires

Direct steering for instant
reaction – answers to the
gentlest touch

All four wheels are individually suspended
and separately torsion-bar sprung

The bottom plate and its steel backbone
combine with the all-steel body to make
a single, torsion-resistant unit

The easy-shifting synchro-
nized transmission has
4 forward speeds
and 1 reverse, all with ideal
gear ratios

The air-cooled 4-cylinder
flat-four engine, economical
and indestructible

Power to spare
at every engine speed

Hydraulic brakes grip all four wheels with smooth,
even power

Engine



AIR COOLING SYSTEM

If you happen to be an automotive engineer or have a good knowledge of engines, a glance at the cut-away view of the power unit will reveal to you the extraordinary perfection of Volkswagen design. Its outstanding features are: compact o. h. v. "oversquare" engine incorporating two pairs of horizontally opposed cylinders – automatically controlled air cooling by fan – four-bearing crankshaft – oil-cooler (a feature normally found only on sports and racing cars) – crankcase requiring only 5 pints of oil – low piston speed – low engine r. p. m., thus minimum wear but maximum efficiency.

These are some of the reasons why Volkswagen engines have such an endurance and long life.

The air-cooled engine is in the rear, where it supplies maximum traction to the drive wheels; together with the carefully graduated synchronized transmission, it makes the Volkswagen a fine mountain-climber (37% grade in low gear). There is no road so steep the VW can't scale it. The more abrupt the grade and the sharper the curve, the better the Volkswagen shows the stuff it's made of.

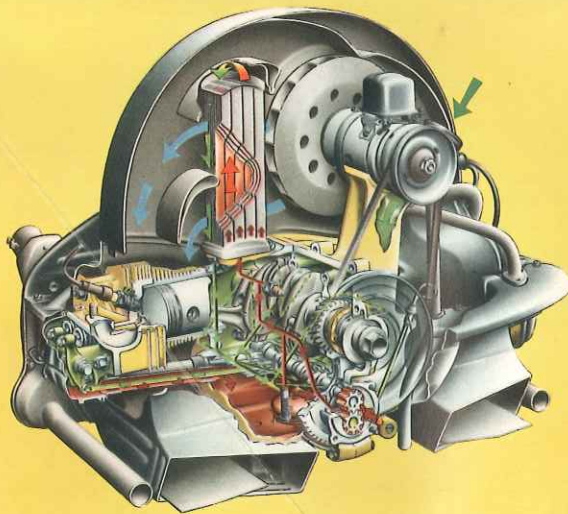
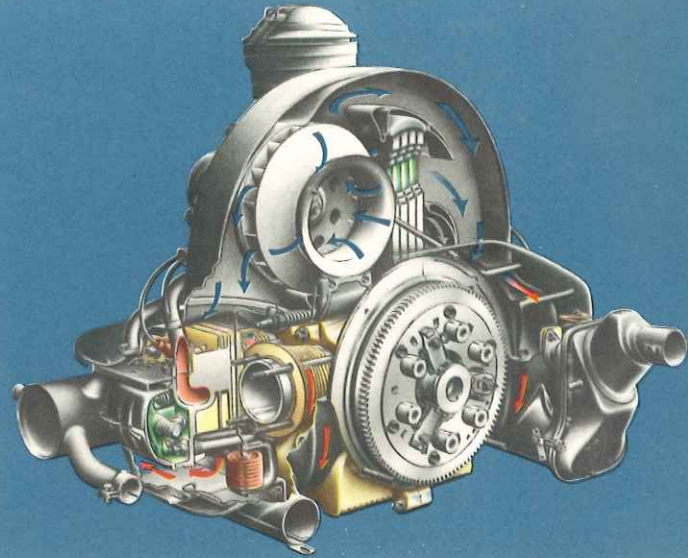

COOLED OIL

Air cooling system: unless you have driven a Volkswagen under all road and weather conditions, at all speeds, you cannot fully appreciate the superiority of its automatically controlled air cooling system. No Volkswagen owner can be bothered by any of the troubles inherent in water-cooled engines. No mountain road is steep enough, no tropical weather hot enough to make the engine overheat; no arctic cold can make it freeze! Under any conditions the "thermostatic" cooling system will supply the proper quantity of air required to cool the engine, which – at full speed – is about 17.5 cubic feet per second.

Cooled oil: the oil-cooler is automatically controlled by thermostat, thereby maintaining proper oil temperature and meeting any other operating requirements. That is why the engine never becomes overstrained, even when driven for hours on end at maximum speed.

Specifications

<i>Engine</i>	4 cylinder, 4-stroke rear engine with horizontally opposed cylinders and air-cooling system; Capacity: 72.740 cu. in. (1192 c. c.); S. A. E. Rating: 36 h. p. at 3700 r. p. m.
<i>Transmission</i>	4 forward speeds and 1 reverse; synchromesh on 2nd, 3rd and 4th gears, silent
<i>Final Drive</i>	Power transmitted through spiral bevel gear, two-pinion bevel differential gear, swing-axle shafts to rear wheels. Reduction ratio 4.4 : 1
<i>Chassis Frame</i>	Tubular centre section forked at rear and welded-on platform
<i>Front Axle</i>	Independent suspension through longitudinal trailing arms, 2 inclosed, laminated, square-section torsion bars
<i>Rear Axle</i>	Independent suspension of wheels through swing-axle shafts with trailing arms, and one round torsion bar on each side
<i>Shock Absorbers</i>	Front and rear: double acting hydraulic telescopic type
<i>Wheelbase</i>	94.5 in. <i>Turning circle</i> 36 ft. <i>Tires</i> 5.60-15, tubeless

<i>Foot Brake</i>	Hydraulic, operating on all four wheels										
<i>Hand Brake</i>	Mechanical, operating on rear wheels										
<i>Track</i>	Front 50.8 in. Rear 49.2 in.										
<i>Fuel Tank Capacity</i>	8.75 Imp. gal. = 10.6 U. S. gal. = 40 l incl. 1.1 Imp. gal. = 1.3 U. S. gal. = 5 l reserve										
<i>Overall Dimensions</i>	<table><tr><td>Length 160.2 in. (4070 mm.)</td><td>Width 60.6 in. (1540 mm.)</td></tr><tr><td>Height 59.1 in. (1500 mm.)</td><td></td></tr></table>	Length 160.2 in. (4070 mm.)	Width 60.6 in. (1540 mm.)	Height 59.1 in. (1500 mm.)							
Length 160.2 in. (4070 mm.)	Width 60.6 in. (1540 mm.)										
Height 59.1 in. (1500 mm.)											
	<table><tr><td><i>Sedan</i></td><td><i>Convertible</i></td></tr><tr><td><i>Net Weight</i> 1565 lbs. (710 kg.)</td><td>1720 lbs. (780 kg.)</td></tr><tr><td><i>Unladen Weight</i> 1609 lbs. (730 kg.)</td><td>1764 lbs. (800 kg.)</td></tr><tr><td><i>Maximum Load</i> 838 lbs. (380 kg.)</td><td>793 lbs. (360 kg.)</td></tr><tr><td><i>Max. Total Weight</i> 2447 lbs. (1110 kg.)</td><td>2557 lbs. (1160 kg.)</td></tr></table>	<i>Sedan</i>	<i>Convertible</i>	<i>Net Weight</i> 1565 lbs. (710 kg.)	1720 lbs. (780 kg.)	<i>Unladen Weight</i> 1609 lbs. (730 kg.)	1764 lbs. (800 kg.)	<i>Maximum Load</i> 838 lbs. (380 kg.)	793 lbs. (360 kg.)	<i>Max. Total Weight</i> 2447 lbs. (1110 kg.)	2557 lbs. (1160 kg.)
<i>Sedan</i>	<i>Convertible</i>										
<i>Net Weight</i> 1565 lbs. (710 kg.)	1720 lbs. (780 kg.)										
<i>Unladen Weight</i> 1609 lbs. (730 kg.)	1764 lbs. (800 kg.)										
<i>Maximum Load</i> 838 lbs. (380 kg.)	793 lbs. (360 kg.)										
<i>Max. Total Weight</i> 2447 lbs. (1110 kg.)	2557 lbs. (1160 kg.)										
<i>Performance</i>	Fuel consumption according to the German (DIN) Standard 70030: 39 miles per Imp. gal., 32 miles per U. S. gal., 7.3 l/100 km. Maximum and cruising speed: 68 m.p.h.=110 km/h. Climbing ability in 1st gear 20.5° (37%)										

Outer mirror at extra cost

V O L K S W A G E N W E R K G M B H
W O L F S B U R G G E R M A N Y